

**Ultra-low TCR, Low Thermal EMF**  
**High-Precision Shunt Based Current Sensing Module**

# HRES6918

Nominal Resistance	<b>50<math>\mu\Omega</math></b>
Initial Resistance Tolerance	<b><math>\pm 0.1\%</math></b>
Tolerance over Full Temperature Range	<b><math>\pm 0.3\%</math></b>
Maximum TCR	<b><math>\pm 15\text{ppm}/^\circ\text{C}</math></b>
Thermal EMF	<b><math>\leq 0.6\mu\text{V}/^\circ\text{C}</math></b>
Rated Current	<b><math>\pm 500\text{A}</math></b>



## Applications

Electric Vehicles / Construction Machinery  
Agricultural Machinery / eVTOL / Energy Storage / Charging Stations  
Power Metering / Precision Power Supply

### Ultra-low TCR, Low Thermal EMF High Measurement Accuracy, Low Resistance, High Current

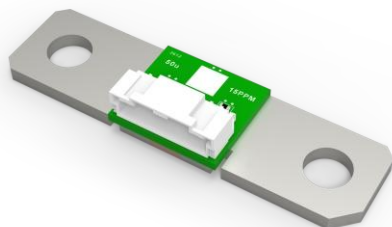

#### Introduction

The HRES6918 series ultra-low resistance shunts, designed for precise measurement of kiloamp-level currents. Through proprietary alloy manufacturing and optimized sensing structure, a maximum TCR of  $\pm 15$  ppm/ $^{\circ}\text{C}$  is achieved, with typical values as low as  $\pm 10$  ppm/ $^{\circ}\text{C}$ . Thermal EMF is reduced to  $\leq 0.6$   $\mu\text{V}/^{\circ}\text{C}$  through precise alloy and customized heat treatment. Initial resistance tolerance is better than  $\pm 0.1\%$ , enabling high-precision sensing without complex TCR compensation. This significantly reduces application and calibration costs.



The module integrates a shunt and PCBA, and can be mounted via bolts in the circuit. Applicable to bus current and shunt temperature and outputs signals to the signal processing module.

#### Electrical Parameters

Resistance	Initial Resistance Tolerance <sup>[1]</sup>	Tolerance over Full Temperature Range <sup>[2]</sup>	TCR	Rated Current	Thermal EMF	Inductance	Operating Temperature
50 $\mu\Omega$ ±5%	±0.1%	±0.3%	±15ppm/ $^{\circ}\text{C}$ (+20~+125 $^{\circ}\text{C}$ , 25 Ref)	±500A	≤0.6 $\mu\text{V}/^{\circ}\text{C}$	≤3nH	-40~+125 $^{\circ}\text{C}$

[1]. Scan the QR Code to get the initial resistance of shunt, at lab environment of +25 $^{\circ}\text{C}$ ±2 $^{\circ}\text{C}$ .

[2]. Resistance tolerance over the full temperature range, -40~+125 $^{\circ}\text{C}$ , is referenced to the initial resistance value.

#### NTC

Resistance	Tolerance	TCR	Operating Temperature Range
10K $\Omega$	±1.0%	-3380ppm/K(25/50 $^{\circ}\text{C}$ )	-40~+150 $^{\circ}\text{C}$

#### Mechanical Dimensions (Unit:mm)

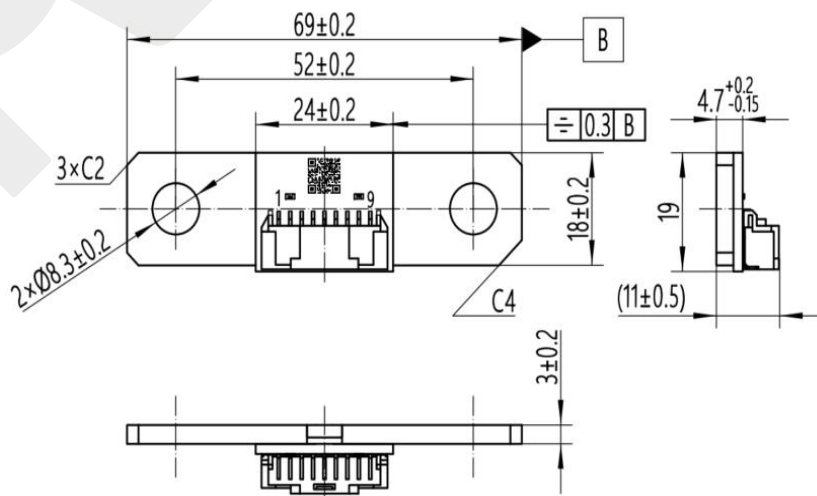

### Part Number Information

Example:HRES6918BL050MST0 (HRES6918  $\pm 0.1\%$   $50\mu\Omega$   $\pm 15$  ppm/ $^{\circ}\text{C}$  Standard)

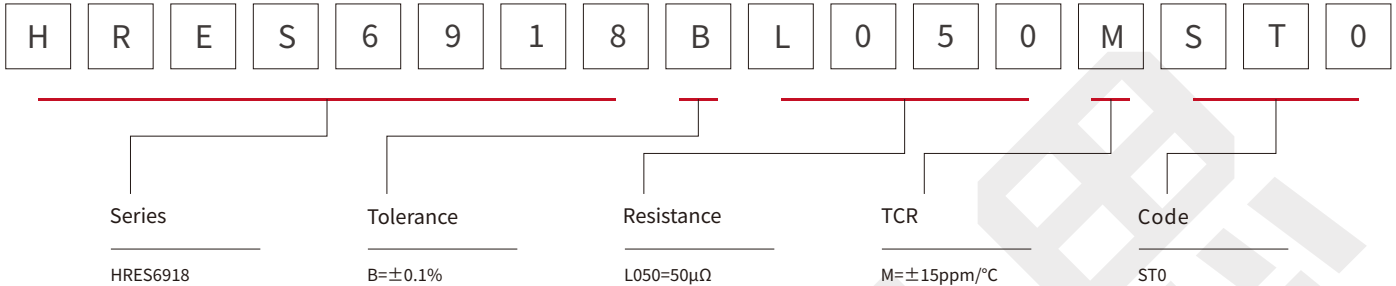

### Electrical Principle

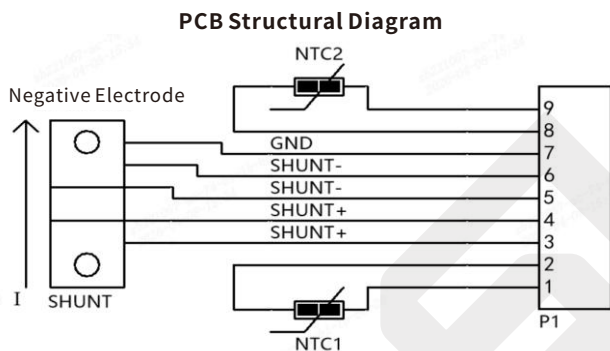

Connector Diagram

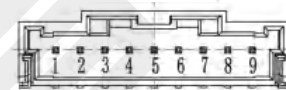

Connector Part Number: 2008WRS-1x09-9TNB05RR02CQ

Pin No.	Code & Description	Code & Description
Pin 1	TL1	Left Temperature Sensor Pin 1
Pin 2	TL2	Left Temperature Sensor Pin 2
Pin 3	SB+	Current Signal Group B Positive
Pin 4	SA+	Current Signal Group A Positive
Pin 5	SA-	Current Signal Group A Negative
Pin 6	SB-	Current Signal Group B Negative
Pin 7	COM	Shunt Common Terminal
Pin 8	TR1	Right Temperature Sensor Pin 1
Pin 9	TR2	Right Temperature Sensor Pin 2

- The current direction depends on the installation position of the product within the BDU and is not related to the HRES6918 module.
- The current direction indicated in the diagram defines the polarity of the pins.
- According to the recommended current direction in the PCB structural diagram, battery discharge is generally defined as positive, while charging is defined as negative.
- The current sensing channels of Group A and Group B are designed as redundant channels and can be used interchangeably.
- Recommend Pin 4 and Pin 5 as twisted pair. Pin 3 and Pin 6 as twisted pair.

### Typical Application

The module is designed for precise current measurement at critical nodes of the system. It integrates a high-power shunt and temperature sensors (NTC), and can be easily integrated with backend circuitry as a front-end signal acquisition device.

The module incorporates a high-power shunt resistor for real-time current measurement, while integrated temperature sensors are used to monitor the shunt temperature, enabling continuous monitor of the system operating temperature. The module interface provides two independent current sensing channels and two temperature sensing channels. The two current sensing groups are designed with redundancy and can be used interchangeably. Similarly, the two temperature sensing channels are implemented as redundant paths, both supporting temperature measurement via a voltage divider method. Both current and temperature sensing signals are routed through a common connector. It is recommended to perform sensing on the same side of the system. Sampling across high side and low side of an isolated system is not recommended due to potential measurement inconsistencies. The sensing signals can be routed via a wiring harness and acquired through backend ADC channels. The overall system typically consists of three main elements: the sensing module, the wiring harness, and the circuit.

Remark:

- In a simplified design, only one current sensing channel and one temperature sensing channel may be used, without redundancy.
- In general applications, resistor (R) and capacitor (C) values can be selected according to the recommended table, or adjusted based on actual requirements.

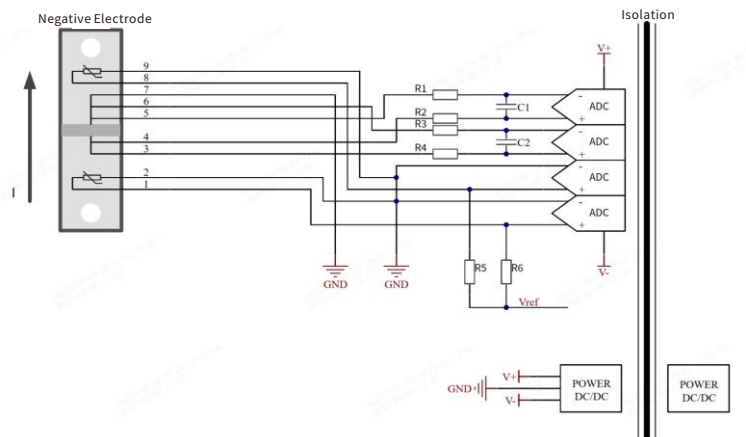

Component	R1, R2, R3, R4	R5, R6	C1, C2
Specifications	20 $\Omega$	20K $\Omega$ 0.1%	1nF

### Performance Specifications

Test	Test Method	Standards	Acceptance Criteria
Electrical Characteristics	Measured at -40°C, 0°C, 85°C, 125°C, and 25°C (25°C as reference)	User Specifications MIL-STD-202H Method 304	Resistance value and TCR shall remain within specified limits. Tolerance shall meet $\geq 1.33$ Cpk capability
Insulation Resistance	1000 V DC, Duration: 60 s	MIL-STD-202H Method 302	Insulation resistance $\geq 10$ MΩ No visible damage, arcing, or breakdown $\Delta R/R \leq \pm 0.25\%$
Dielectric Strength	1000 V AC, 500V/s, Duration: 3 s	MIL-STD-202H Method 301	Leakage current $< 2$ mA No visible damage, arcing, or breakdown $\Delta R/R \leq \pm 0.25\%$
Short-Time Overload	5 × rated power, 5 s, natural convection (no forced airflow)	GB/T 7676.8-2017 5.5.3.2	No visible damage $\Delta R/R \leq \pm 0.5\%$
Low Temperature Storage	-40°C, Duration: 96 h	IEC 60068-2-1:2025	No visible damage $\Delta R/R \leq \pm 1\%$
High Temperature Storage	+125°C, Duration: 2000h	IEC 60068-2-2:2025 MIL-STD-202H Method 108	No visible damage $\Delta R/R \leq \pm 1\%$
Thermal Shock	125°C / -40°C, 15 min dwell (30 min if >28 g), $\leq 30$ s transfer, 1000 cycles	IEC 60068-2-14:2023 Test Na	No visible damage $\Delta R/R \leq \pm 1\%$
Bias Humidity	85°C, 85% RH, 1000 h, 10% rated power	MIL-STD-202H Method 103	No visible damage $\Delta R/R \leq \pm 1\%$
Load Life	125°C (terminal), 2000 h, rated power loaded	MIL-STD-202H Method 108	No visible damage $\Delta R/R \leq \pm 1\%$
Mechanical Vibration	10–1000 Hz, 8 h/axis, 27.1 m/s <sup>2</sup> RMS	ISO 16750-3:2023 4.1.8 IEC 60068-2-64	No functional mechanical damage No component failure $\Delta R/R \leq \pm 0.5\%$
Mechanical Shock	50 g, 6 ms pulse width, 10 shocks per axis (X±, Y±, Z±)	ISO 16750-3:2023 4.2.2	No functional mechanical damage No component failure $\Delta R/R \leq \pm 0.5\%$
Free Drop	Concrete floor or steel plate, 1m, 3 samples, 2 drops per sample	ISO 16750-3:2023 4.3	$\Delta R/R \leq \pm 0.5\%$
Visual Inspection	Visual inspection or optical inspection with suitable magnification	MIL-STD-883L Method 2009.14	No marking defects, burrs, scratches, deformation, or soldering defects No component failure
Dimensions	Full dimensional measurement per product specification	JESD22-B100B	Complies with product datasheet specifications
Weight	Measured using a precision electronic balance	Product Datasheet	Complies with product datasheet specifications
Flatness	Measured using a height gauge or profilometer at electrical connection area	Product Datasheet	Complies with product datasheet specifications

### Derating Curve

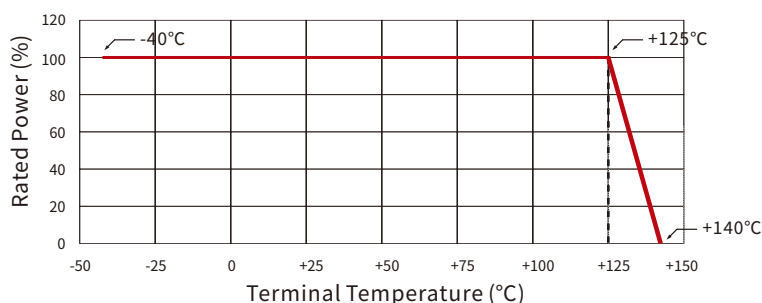

### NTC Resistance - Temperature Table

Typical Resistance vs. Temperature ( Resistance in: KΩ, Temperature in: °C)

°C	0	+1	+2	+3	+4	+5	+6	+7	+8	+9
-40	216.2	203.9	192.4	181.7	171.6	162.2	153.3	145.0	137.2	129.9
-30	123.0	116.5	110.4	104.7	99.25	94.16	89.37	84.85	80.59	76.57
-20	72.77	69.20	65.82	62.63	59.61	56.76	54.06	51.50	49.08	46.79
-10	44.62	42.55	40.59	38.74	36.98	35.31	33.72	32.22	30.79	29.44
0	28.15	26.93	25.77	24.66	23.61	22.61	21.66	20.75	19.89	19.06
10	18.28	17.53	16.82	16.13	15.48	14.86	14.27	13.71	13.17	12.65
20	12.16	11.69	11.24	10.81	10.39	10.00	9.622	9.269	8.933	8.610
30	8.301	8.005	7.721	7.449	7.188	6.937	6.696	6.465	6.243	6.029
40	5.824	5.627	5.437	5.254	5.078	4.909	4.746	4.590	4.439	4.294
50	4.159	4.020	3.890	3.765	3.645	3.529	3.417	3.309	3.205	3.105
60	3.008	2.916	2.828	2.742	2.660	2.580	2.503	2.429	2.358	2.289
70	2.222	2.157	2.095	2.034	1.976	1.919	1.865	1.812	1.761	1.711
80	1.663	1.617	1.573	1.530	1.488	1.447	1.408	1.370	1.334	1.298
90	1.264	1.230	1.197	1.166	1.135	1.106	1.077	1.049	1.022	0.9955
100	0.9700	0.9455	0.9217	0.8986	0.8763	0.8545	0.8334	0.8128	0.7930	0.7736
110	0.7548	0.7365	0.7188	0.7015	0.6848	0.6685	0.6527	0.6373	0.6223	0.6078
120	0.5936	0.5799	0.5665	0.5536	0.5409	0.5285	0.5170	0.5054	0.4941	0.4831
130	0.4723	0.4619	0.4517	0.4417	0.4321	0.4226	0.4135	0.4046	0.3958	0.3874
140	0.3792	0.3711	0.3633	0.3557	0.3482	0.3409	0.3339	0.3270	0.3202	0.3138
150	0.3073									

### Construction

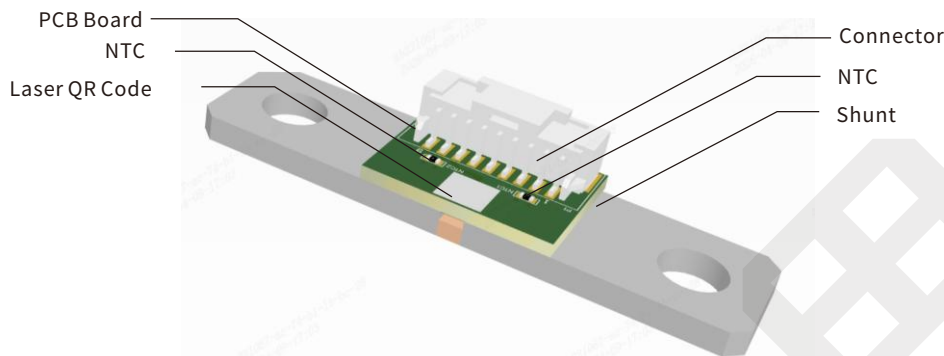

### Marking

Part Number	Illustration	Laser QR Code	Example
HRES6918BL050MST0		Data Matrix Size: 5*5mm, Total Characters Digits: 22	Number: 2026032000001R049.8395 Decoded Information: Date: March 20, 2026; Module ID: 00001; Initial Resistance: 49.8395 $\mu\Omega$

### Copper Bar Connection

1. Recommended busbar material: T2 copper
2. Recommended busbar dimensions: Width: 25 mm, Thickness: 3 mm; Single-side length greater than 20 mm. The busbar should be positioned as far as possible from the shunt resistor and the wiring harness heat sources.
3. Recommended bolt: M8
4. Recommended tightening torque: 15–20 N·m
5. Do not use a flat washer between the copper bar and the shunt
6. Keep the surfaces of the shunt and copper bar clean and free of scratches

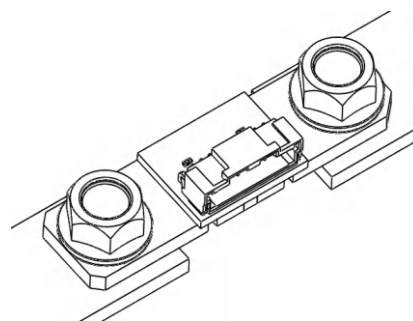

### Storage

1. Recommended storage at room temperature
2. The storage environment shall be clean, dry, and free of harmful gases. The packaging must be protected from direct sunlight
3. Anti-static wrist straps or gloves should be worn during installation, storage, and handling
4. Avoid mechanical impact during handling

### Packaging

Package Element	L	W	H
Carton	509	342	240
EPE Tray	496	328	61
Tray Cover	495	325	5
Anti-static Bag	900	510	

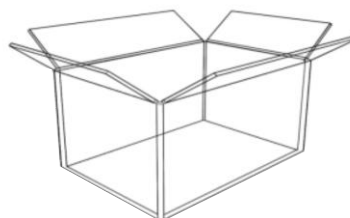

Carton Diagram

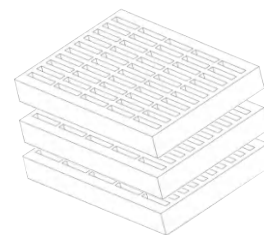



EPE Tray Diagram

Unit:mm

Quantity: 50 pcs/ EPE Tray, every 3 tray in a carton, the full carton package covers 150 pcs.

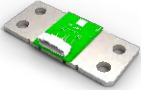
### High-Precision Current Sensing Module

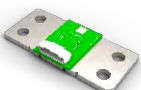
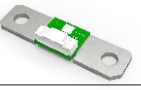
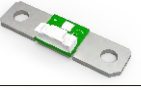
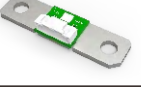
Part Number	Module Illustration	Resistance Value Range	Tolerance over Full Temperature Range	Rated Current	TCR	Thermal EMF	Operating Temperature
HRES8436BL015MST0		15μΩ±5%	±0.3%	±1200A	±15ppm/°C (+20~125°C, 25 Ref)	≤0.6μV/°C	-40~125°C
HRES8436BL025MST0		25μΩ±5%	±0.3%	±1000A	±15ppm/°C (+20~125°C, 25 Ref)	≤0.6μV/°C	-40~125°C
SRES8436BL050VST0		50μΩ±5%	±0.3%	±800A	±5ppm/°C (+20~125°C, 25 Ref)	≤0.6μV/°C	-40~125°C
HRES6918BL025MST0		25μΩ±5%	±0.3%	±600A	±15ppm/°C (+20~125°C, 25 Ref)	≤0.6μV/°C	-40~125°C
HRES6918BL050MST0		50μΩ±5%	±0.3%	±500A	±15ppm/°C (+20~125°C, 25 Ref)	≤0.6μV/°C	-40~125°C
SRES6918BL100VST0		100μΩ±5%	±0.3%	±400A	±5ppm/°C (+20~125°C, 25 Ref)	≤0.6μV/°C	-40~125°C

### Revision

Version	Revised Content	Date	Approver
V0	Initial Issue	2026/4/20	LWW
V1	Change NTC	2026/5/8	LWW

---

## Disclaimer

All products, datasheets and data can be changed without prior notice.

C&B Electronics Shenzhen CO., LTD., its affiliates, distributors, employees, and any other person acting on its behalf (collectively referred to as "C&B Electronics") shall not bear any legal responsibility for any errors, inaccuracies, or incompleteness of information related to the product disclosed under this agreement or other disclosures.

Product datasheet does not constitute an extension or revision of the purchase terms and conditions in C&B Electronics, including but not limited to the warranties under this agreement.

Unless specified in the purchase terms and conditions, C&B Electronics makes no guarantees, representations or warranties.

**To the maximum extent permitted by applicable laws, C&B Electronics hereby makes the following disclaimer:**

- (1) All liabilities arising from the use of the product;**
- (2) Including but not limited to all liabilities arising from special, indirect or incidental damages;**
- (3) All implied warranties, including warranties of suitability for special purposes, non infringement possibility, and marketability.**

The information provided in the datasheet and parameter tables may vary in different applications, and the performance of the product may change over time. The recommended application instructions for the product are based on C&B Electronics' understanding and experience of typical requirements. Customers are obligated to verify whether the product is suitable for a specific application based on the parameters provided in the datasheet. Before officially installing or using the product, you should ensure that you have obtained the latest version of relevant information, which can be obtained through the website: [resistor.today](http://resistor.today).

The signing of this agreement does not constitute an express, implied or other form of license related to all intellectual property rights of C&B Electronic Products.

Unless explicitly stated, the products listed in this agreement are not applicable to lifesaving or life sustaining products. In the absence of a clear indication, the customer shall bear all risks caused by unauthorized use of the above products and agree to fully compensate C&B Electronics for all losses caused by such sales or use. For written product terms for such special applications, please contact authorized personnel from C&B Electronics to obtain.

The names and markings on the listed products may be trademarks owned by others.